



# SQ2 System

Cat# SQ2KIT  
ASSEMBLY INSTRUCTIONS



**Includes:**

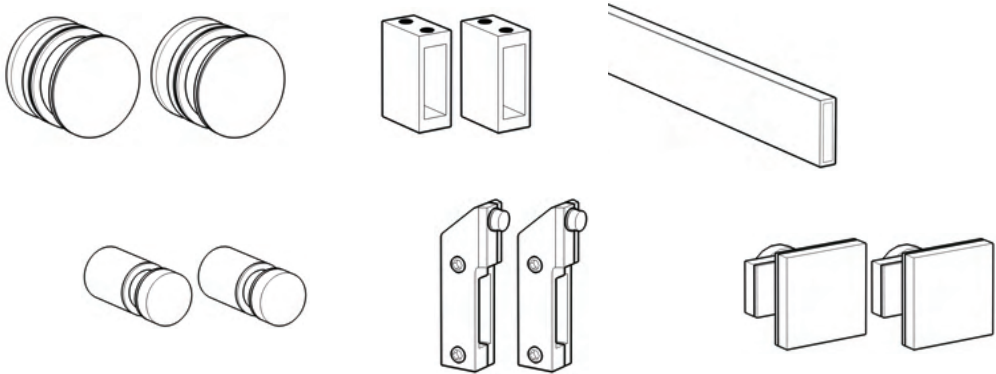

**General Dimensions**

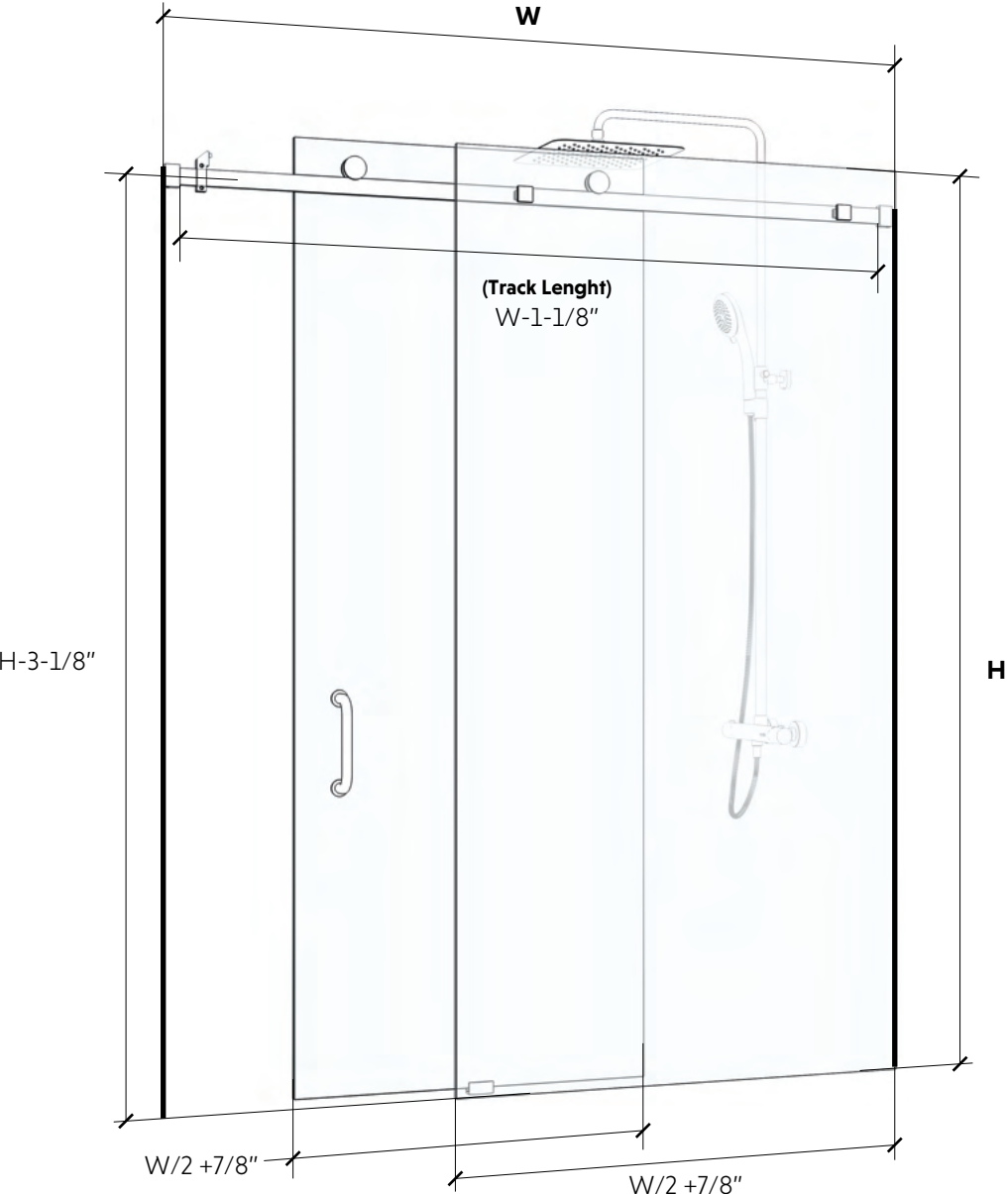

1.

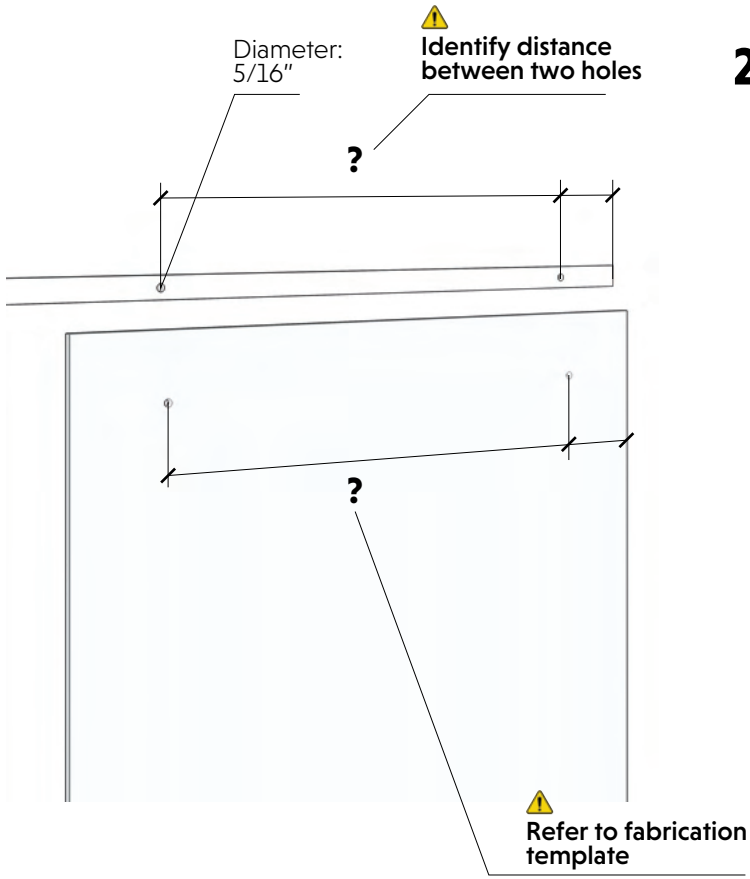

2.

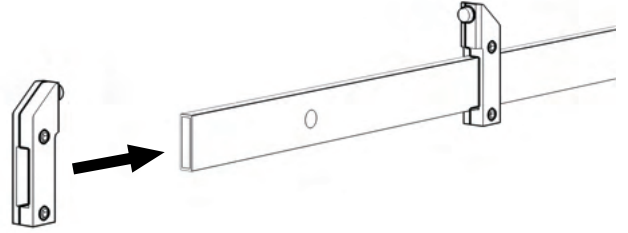

3.

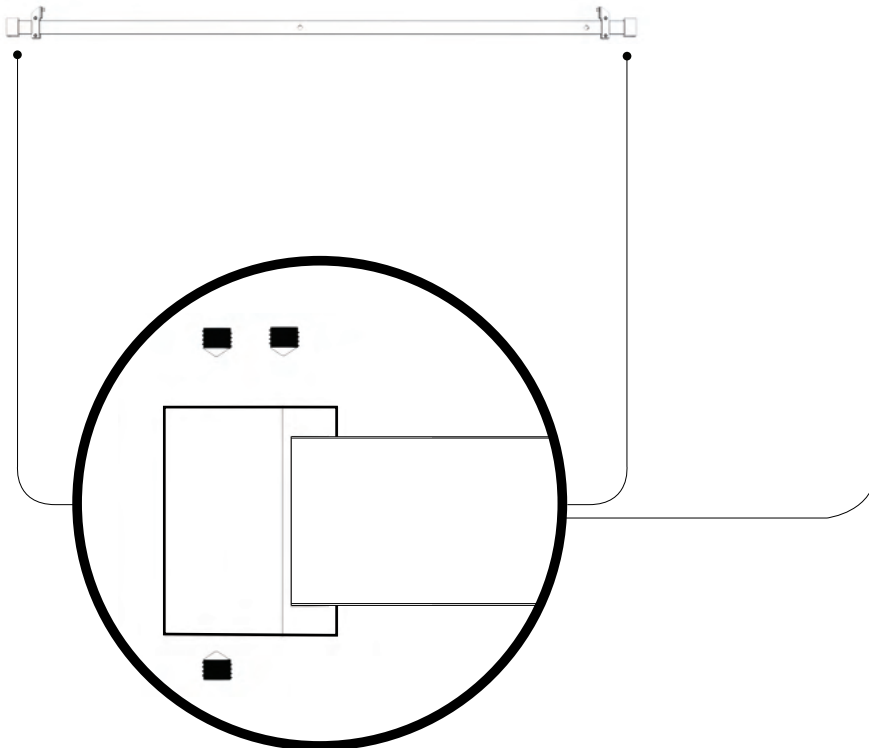

a.

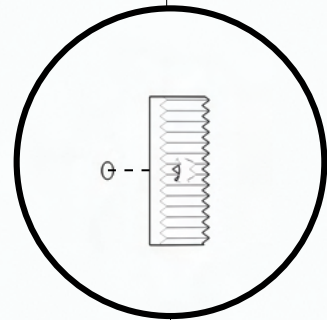

b.

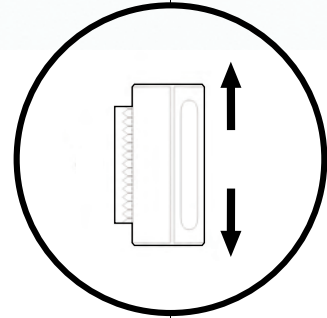

c.

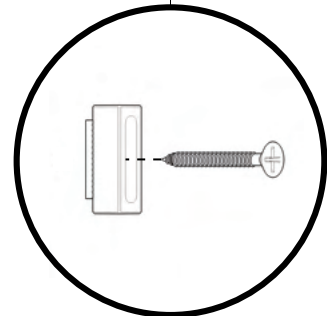

4.

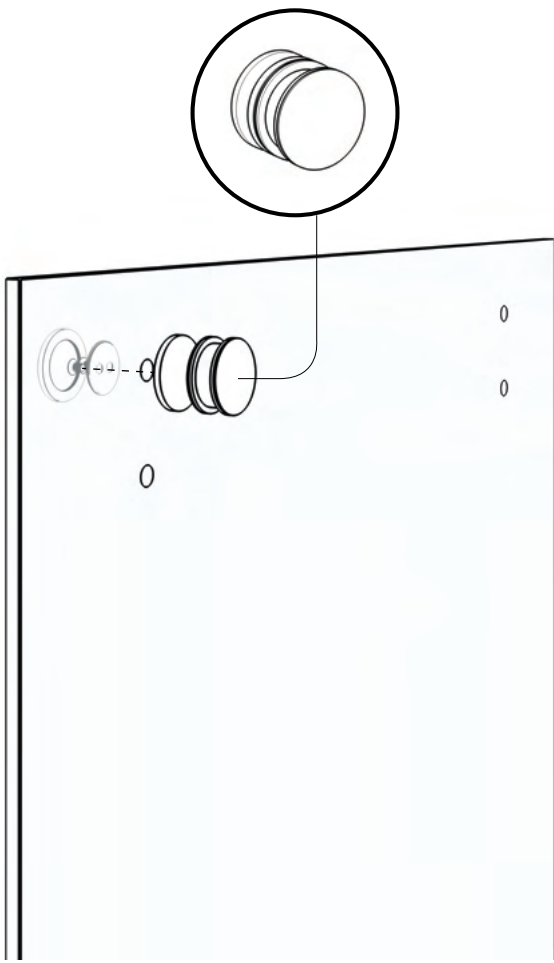

6.



7.

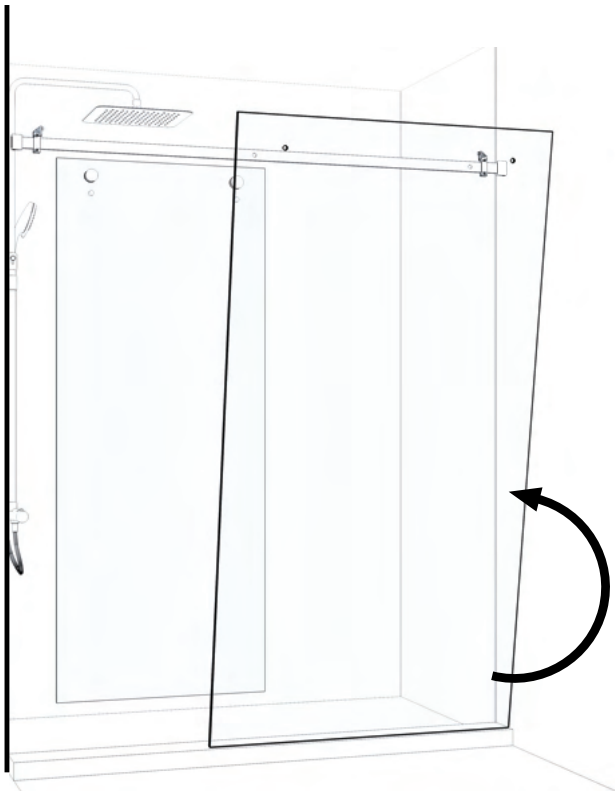

8.

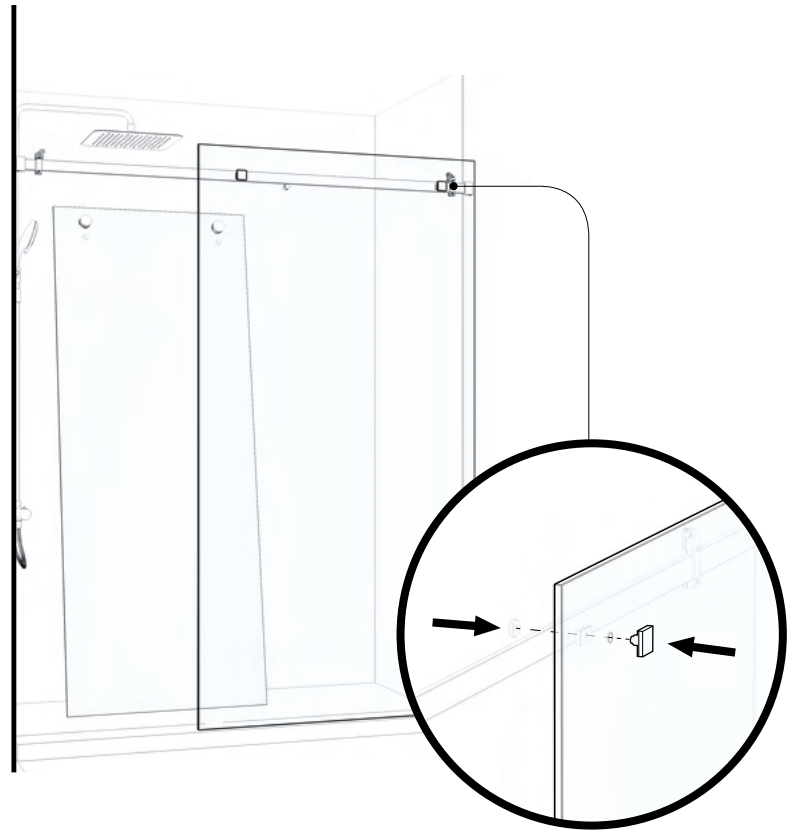

9.

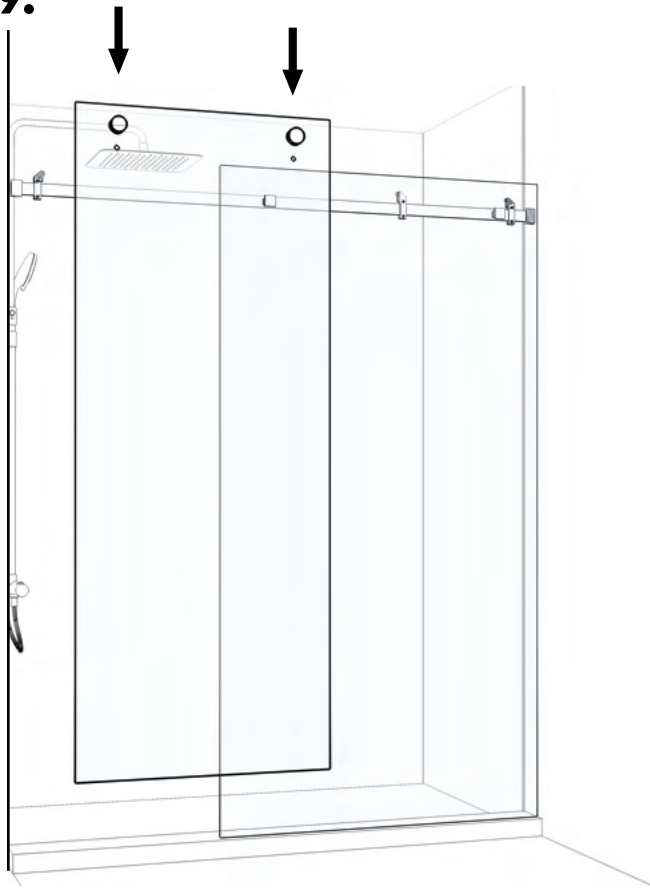

10.

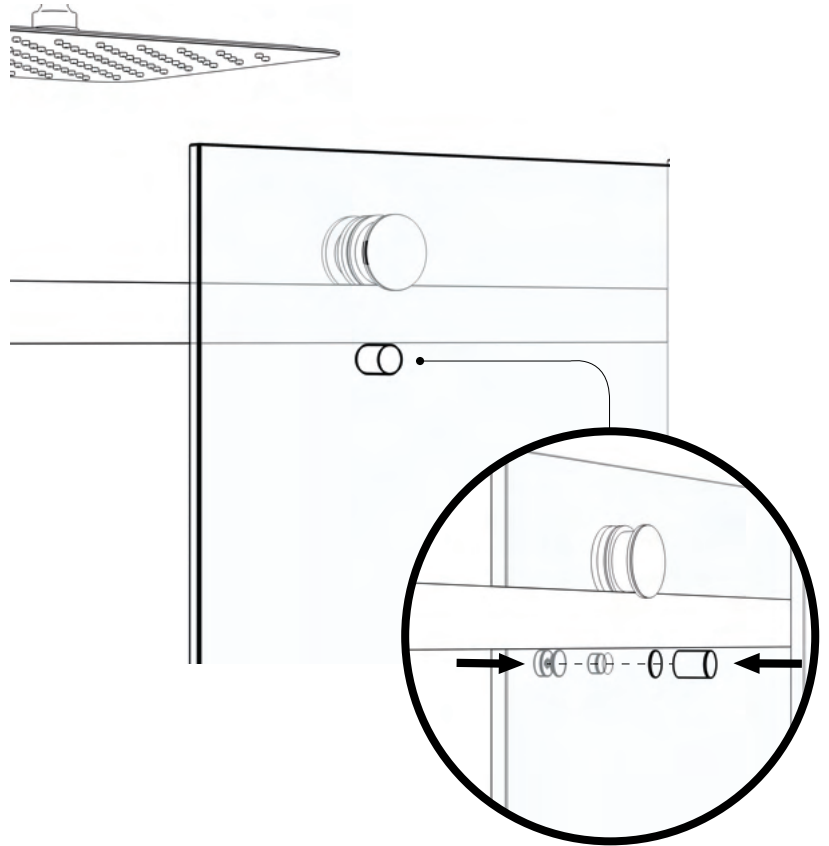

11.

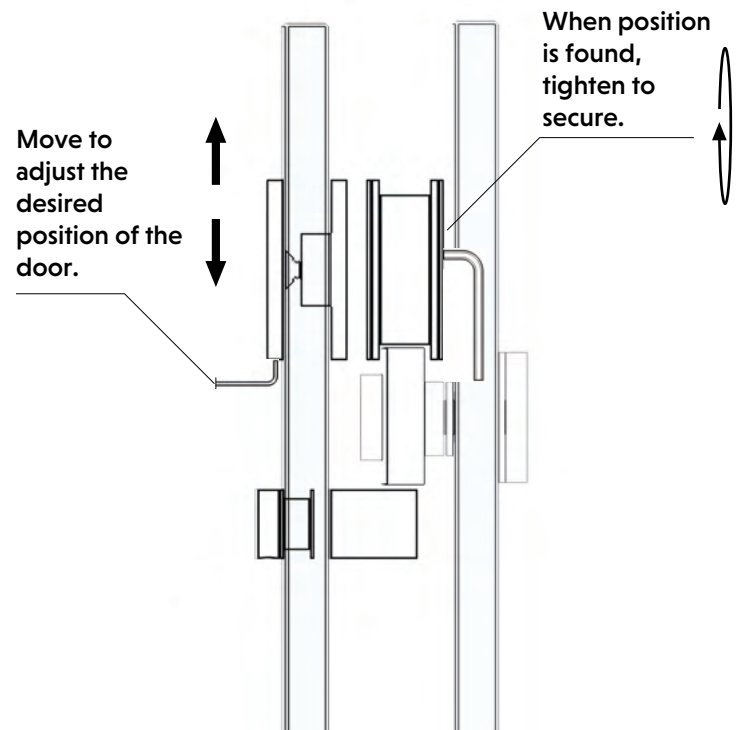
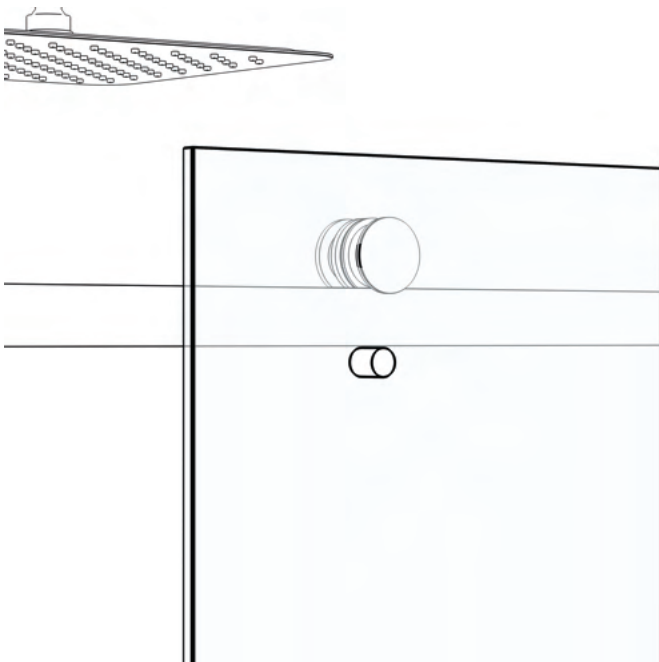

12.

